

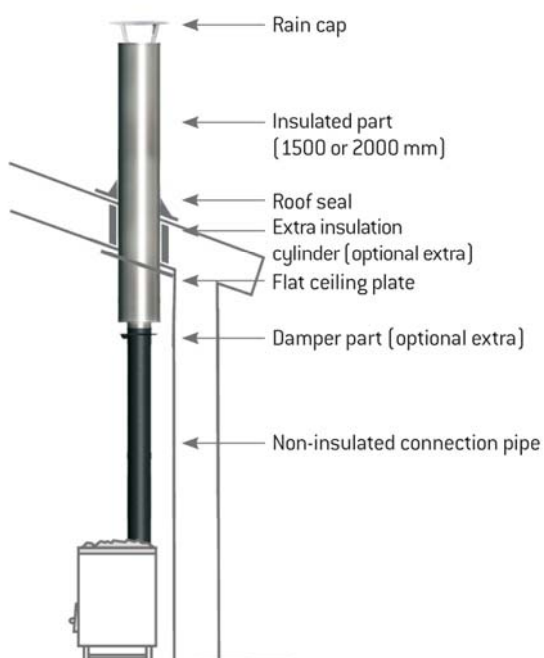

KASTOR

Kastor Oy, Tehtaankatu 5-7
11710 Riihimäki, Finland
www.kastor.fi



KASTOR CHIMNEY SET INSTALLATION MANUAL

1. BEFORE YOU INSTALL	1
1.1. Inspection of the delivery	1
1.2. Matters and regulations to be considered prior to installation	1
1.3. Safety distances and protective casing.....	1
1.4. Surface treatments.....	2
1.6. Basic installation set and its parts.....	3
2. INSTALLATION	3
2.1. Foundation	3
2.2. Supports and snow insulation for the Kastor Chimney	3
2.3. Kastor Chimney height dimensioning and extensions	4
2.3.1. Instructions from the E3 building code.....	6
2.4. The connection pipe and its safety distance.....	6
2.5. Extension pipe.....	6
2.6. Damper part J130S141 and J103S142.....	6
2.7. 100 mm Kastor Chimney, insulated part.....	6
2.8. 130 mm Kastor Chimney, insulated part.....	6
2.9. Flat ceiling plate KC-98 and KC-99.....	7
2.10. KC insulation cylinder.....	7
2.11. KC Rain collar (chimney root seal)	7
3. USING THE CHIMNEY	8
4. CHIMNEY MAINTENANCE	8
5. IMPORTANT FACTORS, RULES AND REGULATIONS	8
5.1. Warranty.....	8
5.2. Technical data.....	9

Save these instructions for later use.

Once the installation is completed, this manual should be given to the owner of the chimney or the person responsible for operating it.

Read these instructions before installation and use.

This installation manual is updated 10.9.2008/Pto

1. BEFORE YOU INSTALL

Inspect the delivery as soon as you receive it. Report any transport damages to the deliverer.

1.1. *Inspection of the delivery*

A normal delivery includes

- the ordered chimney elements and CE decals (2)
- installation manual.

The equivalence of the delivery to the order document must be checked as soon as possible. Any missing, defective or wrong parts must be reported immediately to the supplier. When the missing or faulty parts are due to the supplier, he will deliver the required new parts as soon as possible to the assembly site.

The manufacturer and supplier do not take responsibility for costs arising from indirect damage, delays, work stoppages etc.

1.2. *Matters and regulations to be considered prior to installation*

Remember to account for the E3 regulations of the Finnish building code or equivalent regulations in Your country of residence regarding the height of the chimney with regard to the highest part of the roof. See chapter 2.3.1 Illustration 3.

Check the following as well:

- The installation permits for the chimney are in order
- The chimney's length and its inner pipe's internal diameter are in accordance with the fireplace's manufacturer's instructions
- Prior to cutting the through holes, make sure there are no floor joists or wall supports in the way
- Ensure beforehand by measuring that any extension pieces will not be going through floors or the roof. See chapter 2.3. Illustration 2

1.3. *Safety distances and protective casing*

ATTENTION! Disregarding these instructions may cause fire hazards!

With regard to safety distances, the E3 regulations of the Finnish building code or equivalent regulations in Your country of residence must be adhered to.

Flammable parts of the building must be situated so far from the outer surface of the flue channel that their temperature cannot rise beyond +85° Celsius (+185° Fahrenheit), but with a minimum distance of 50 mm.

In flammable building parts, such as floors and ceilings, the through hole will be equipped with insulated piping and a 100 mm thick layer of non-flammable material such as fire wool or fibreglass/ceramic matting with a specific weight of at least 100 kg/cubic metre. When the Kastor K extra insulation cylinder is used, the additional insulation layer is not necessary.

Chimney safety distances:

If the flue channel borders a cupboard or other storage space, the protective casing against the chimney's mantle must not contain insulation and the casing must have a ventilated airing slot to prevent overheating in the storage space and chimney.

If there needs to be casing for some reason, the casing must be made of non-flammable material and have sufficient internal ventilation. We recommend conferring about the details with your local fire department's fire inspector.

The safety distance for non-insulated connection pipes and extension pipes is 1000 mm. This distance can be reduced by 50 % with a lightweight, single layer protection and by 75 % with a double layer. This protection can consist of either 1 mm thick metal sheeting or 7 mm thick fibre-reinforced cement panels (not gypsum panels with paper surface). Leave a ventilation gap of 30 mm between wall and protective layer and keep them detached from floor and ceiling.

Width and height of the protection are defined according to the 1000 mm rule mentioned above, so that the minimum distances from the bare pipe to flammable material are kept. The lower part of the insulated flue channel must extend at least **400 mm** downwards from the ceiling. The reducer cone of a semi-insulated chimney can be right below the ceiling.

The safety distance is always measured from flammable material to the heating device or flue pipe. When the connection pipe is used, there must be at least 400 mm of insulated pipe segment below the ceiling.

1.4. Surface treatments

Usually, the mantle of a Kastor Chimney is stainless steel. It may also be painted at the installation site. The chosen paints and coatings must be suited to the estimated maximum temperatures and the stresses of outdoor weather. During correct use, the chimney mantle's temperature never rises beyond +80°C/+176°F.

In saunas temperatures rise significantly. For instance, the temperature above the sauna stove may be +250°C/482°F. If a surface treatment is desired for these situations, you must use heat-resisting paint (minimum of +500°C/932°F).

In dry indoor surroundings, the Kastor Chimney can be clad with another metal mantle (stainless steel, copper, brass etc.) for visual effect, but this must not interfere with inspection and maintenance. Where necessary, sufficient cooling must be ensured by arranging air circulation between the two mantles.

1.6. Basic installation set and its parts

KASTOR CHIMNEY SET

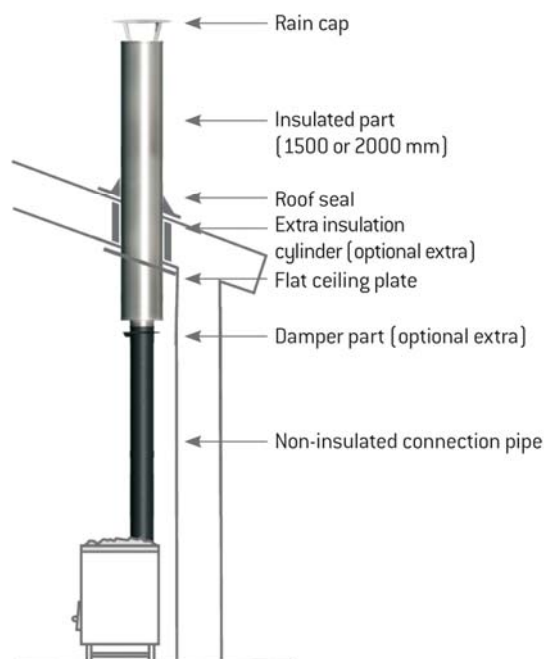

Illustration 1. Basic installation set and its parts

2. INSTALLATION

A Kastor Chimney can be installed in a finished or semi-finished building. The roof piercing is best done in a finished roof to ensure that the piercing is in the right spot.

The insulated part is delivered in two segments (see chapter 2.3). Push them inside each other and fix them with a tie ring. The tie ring's and chimney mantle's grooves must be aligned before tightening.

The CE mark decal is attached close to the lower part of the chimney or an easily visible part of it. The installer fills in the installation date and his/her signature. The other decal is appended to the house's documents and filled with the same information.

Before you start the installation, read chapter 5: Important factors, rules and regulations.

2.1. Foundation

The fireplace and its foundation must be immovable, horizontal and sufficiently stable. They must also withstand the weight of the Kastor Chimney and stresses caused by other factors. A Kastor Chimney must always be vertically installed.

2.2. Supports and snow insulation for the Kastor Chimney

The Kastor Chimney is supported as follows while adhering to safety distances:

The Kastor Chimney rests on the connection pipe and any extensions on top of the fireplace. Where the non-insulated connection pipe is extended with non-insulated extension pipe, their free, unsupported height can be at most two metres. At normal ceiling heights (less than 3 metres), sufficient side support is gained through the flat ceiling plate and the roof attachments. If the unsupported height exceeds 3 metres, the chimney must be supported with braces or wall supports. Note that these must not be attached to non-insulated pipes.

Above the roof the Kastor Chimney must be braced, if it extends more than 1.5 metres. If there is a risk of snow and ice accumulating on the roof and stressing the chimney and its rain collar, it must be protected with a snow barrier.

2.3. Kastor Chimney height dimensioning and extensions

The Kastor Chimney package includes:

- A non-insulated connection pipe of 1000 mm, which can be shortened (permitted minimum length 500 mm)
- The insulated section of 1500 or 2000 mm is always delivered in two parts, which must be connected to each other with a tie ring:
 - 1500 mm (lower part 500 mm + upper part 1000 mm)
 - 2000 mm (lower part 1000 mm + upper part 1000 mm)
- The supporting flat ceiling plate, which is suited for ceiling inclinations of 0°-30°.
- Roof seal KC (to seal the chimney root)
- Rain cap (slide on top of the upper element and tighten in place)

Attention!

According to building and fire safety codes, pipe connections must not be within ceilings or roof structures. The tie ring cannot be tightened within a structure, either.

The insulated part must also extend at least 400 mm below the ceiling above the stove. These requirements can be met by shortening or extending the connection pipe so that the joint of the insulated elements with its tie ring comes below the sauna ceiling and there is the required amount of insulated piping beneath the ceiling. The chimney's joints must not fall within the ceiling's or roof's structural parts.

The following can be used as a guide in dimensioning from the ceiling downwards:

- Kastor Chimney 1500 mm, the lower edge of the insulated part extends about 600 mm below the ceiling so that lower segment and the tie ring remain below, 300 mm are within the roof and, depending on the roof's angle, 550-600 mm remain above the roof.
- Kastor Chimney 2000 mm, the lower edge of the insulated part extends about 600 mm below the ceiling so that lower segment and the tie ring remain below, 300 mm are within the roof and, depending on the roof's angle, about 1100 mm remain above the roof.
- If the chimney extends through a floor and the roof, their distance must be accounted for so that the joint of a Kastor Chimney 2000 mm does not end up within the roof.
- See instructions about shortening and lengthening the chimney below illustration 2.

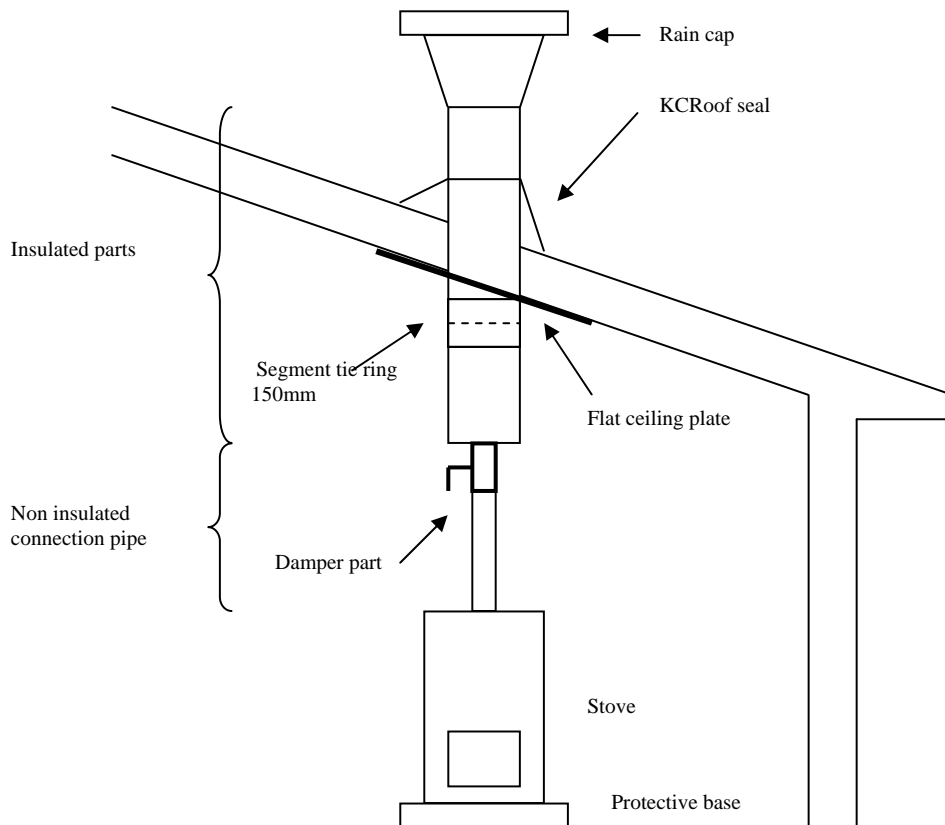

Illustration 2. Example of the dimensioning of the segments in a Kastor Chimney 1500 mm

Shortening or extension of pipe as needed

- If the connection pipe needs to be shortened by sawing, the cut must always be at a 90° angle to the pipe's length
- The connection pipe can also be extended with an extension pipe. The extension pipe comes with a jointing sleeve for easy attachment
- The isolated part can be extended using the Kastor Modular Chimney's K extension parts (250, 500 and 1000 mm)
- All segments are installed with the female end up and attached with tie rings
- Permitted maximum height is 5000 mm. Remember the bracing above the roof where necessary.

2.3.1. Instructions from the E3 building code

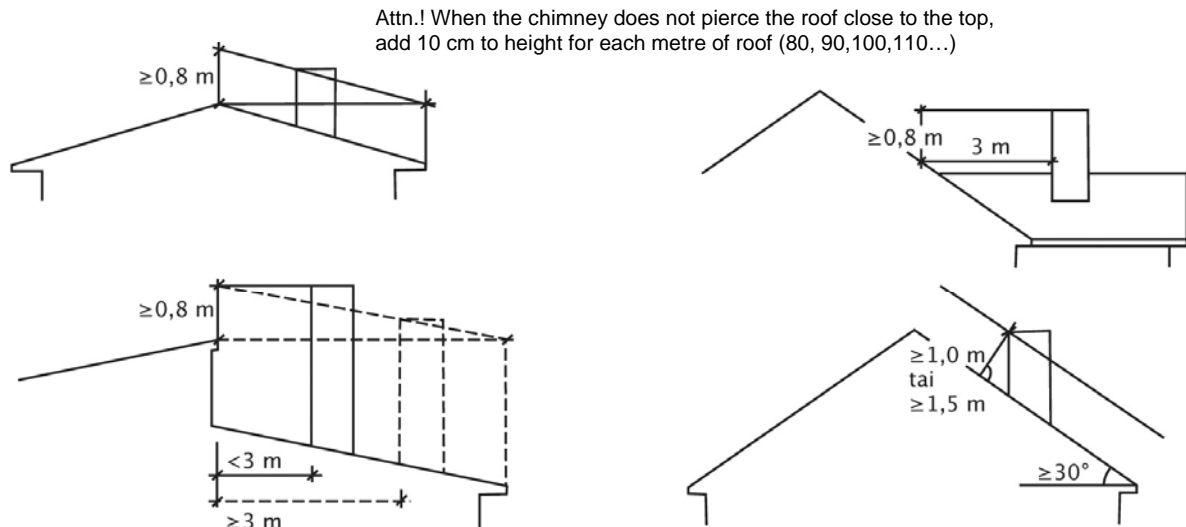

Illustration 3. Instructions from the Finnish E3 building code regarding chimney height in relation with the roof's highest point.

2.4. The connection pipe and its safety distance

The non-insulated connection pipe that comes as standard with the chimney is used when the pipe does not start out insulated from the top of the device, for instance in sauna stoves. There are two sizes of connection pipe (100 and 130 mm), designed for chimneys and device flue openings of various sizes. The connection pipe fits Kastor fireplaces directly using their own adapters. The connection pipes can be shortened by sawing and lengthened using extension pipes (see next chapter). When using non-insulated connection pipe, its minimum safety distance of 1000 mm must be accounted for. When the pipe needs to be shortened by sawing, it is essential that the cut is perpendicular to the length of the pipe. When the damper part J130S141 or J103S142 is used, it must be located between the non-insulated pipe and the insulated segment.

2.5. Extension pipe

The extension pipe is used to lengthen the non-insulated connection pipe when more than 1000 mm of non-insulated piping is needed. The extension pipe comes with a jointing sleeve for joining the pipes together. The length of the non-insulated piping can be adjusted by sawing off the excessive length (see chapter 2.3 about dimensioning). The cut must always be perpendicular to the length of the pipe. The combined length of connection pipe and extension pipe must not exceed 2000 mm.

Never use more than a single extension pipe. It is subject to the same safety distance regulations as the connection pipe, see chapter 2.4.

2.6. Damper part J130S141 and J103S142

We recommend the use of a damper part. Its place is between the non-insulated connection pipe and the insulated part.

2.7. 100 mm Kastor Chimney, insulated part

The chimney's insulated portion is either 1500mm or 2000mm long and always delivered in two segments, which are joined with a tie ring.

2.8. 130 mm Kastor Chimney, insulated part

The chimney's insulated portion is either 1500mm or 2000mm long and always delivered in two segments, which are joined with a tie ring.

2.9. Flat ceiling plate KC-98 and KC-99

The flat ceiling plate is used to support the chimney from the underside of the roof. It can also be used in conjunction with an extra insulation cylinder. It is either attached directly to the ceiling or a wooden structure of suitable size is built, to which the flat ceiling plate is attached by its edges. The ceiling plate is suited both to flat and inclined ceilings. It can also be installed afterwards, when the chimney has already been erected. The ceiling plate consists of two equal parts, which are pushed against the chimney. With an inclined ceiling, the plate may be adapted by cutting it with tin shears. In wooden buildings, the natural movement of the house must be accounted for.

2.10. KC insulation cylinder

The insulation cylinder is recommended for use as a fire safety measure in conjunction with the flat ceiling plate for piercing flammable roofs and walls. It replaces an alternative 100 mm fire wool layer. The cylinder is 500 mm long and contains 50 mm of insulation, which together with the tin cylinder provides sufficient insulation.

Make a hole with a diameter that is 105 mm bigger than the chimney mantle. The chimney is supported by the flat ceiling plate, which is screwed to the ceiling.

2.11. KC Rain collar (chimney root seal)

The rain collar is suited for roofs with an incline of 0-45° covered with felt- or tin and many plate or tile roofs, if their profile does not prevent a good attachment of aluminium and glue.

On a metal-sheeted roof we recommend using a ridge flashing sheet (KC Roof ridge cylinder flashing extension sheet 1250 mm x 800 mm, stainless steel). The sheet must reach from the ridge to the top of the back edge of the rain collar, using the necessary amount of extension sheets. The ridge flashing must extend at least 50 mm onto the top of the rain collar's back edge.

If the roof piercing goes through the seam of a machine-seamed roof, the ridge flashing needs to be made by a qualified roofing firm.

The rain collar is glued to the roof (using, for instance, Würth or Sikaflex glue/sealing compound or an equivalent product). The roof must be completely dry before you glue the chimney root's sealing into place. It is not enough that the surface feels dry. It must be internally dry, as well. The glue manufacturer's instructions regarding temperatures must also be accounted for.

Installation steps:

1. A suitable hole for the chimney is opened into the rubber collar as follows:
 - Cut a knife mark into the front of the ripping tab at the correct spot for the chimney's external diameter:

Chimney (internal diameter)	External diameter	Marking for the ripping spot	Without marking, counting from inner ring
100	215	225	first
130	245	250	second

- Pull by the ripping tab to remove a piece that leaves a smaller hole than needed.
 - Stretch the rain collar carefully over the chimney mantle.
2. Check that the rain collar settles evenly on the roof according to its incline. On a tile roof, the collar is pressed against the roof to make it bend into the correct shape and installed by at least 50 mm underneath the upper tile and by the same amount on top of the lower tile.
3. Make sure it does not overlap the lower tile's border and cut it to size, if necessary.
4. Glue the parts of the rain collar that contact the roof into place with glue/sealing compound.
5. The rubber's upper end is sealed against the chimney with a clip (included in the package).

3. USING THE CHIMNEY

Make sure that the chimney is swept regularly and check it visually at least once a year. The lifespan of the chimney is most affected by the material burned in the furnace and the way it is burned.

4. CHIMNEY MAINTENANCE

Good chimney maintenance includes regular check-ups at sufficiently frequent intervals, i.e. monthly, and, if needed, with the help of the chimney sweeper. If the chimney has been unused for a long period, make sure before you use it that it is in good condition and not blocked (for instance by a bird nest).

A Kastor Chimney should be swept with a stainless and acid-proof or nylon brush.

5. IMPORTANT FACTORS, RULES AND REGULATIONS

The Kastor Chimney has been designed for use only as a flue channel for the flue gases emitted by fireplaces that are used according to regulations. Emissions that differ from the regulations (e.g. heat, pollutants) may damage the chimney. To prevent damage to the flue channel, avoid burning plastics or material that includes plastic (possible creation of hydrochloric acid, for instance). Various glues may also contain plastic or other pollutants, which is why glued pieces must not be burned in the fireplace.

Always check that the fireplace and its accessories are in a condition that ensures clean flue gas. The condition of the chimney must be checked regularly, i.e. once a month!

In addition to these instructions and official regulations, the instructions given by the fireplace's manufacturer must also be heeded, as well as the limits set by the output of fireplaces to various types of chimneys. The temperature of flue gases as they exit the fireplace must not exceed 600°C/1112°F for more than short periods. Sauna stoves can at times produce flue gases that are this hot.

It must also be noted that according to the building code (E3), chimneys must not have horizontal draughts.

In exceptional wind conditions, such as on outer islands, horizontal rain may enter the chimney. After such circumstances, the sauna stove must be checked for water. If necessary, dry it by holding the stove's door and ash receptacle open.

The matters presented in these instructions are valid only for parts manufactured by Kastor Oy. Kastor Oy does not take responsibility for cases in which parts from other manufacturers were attached to our systems.

If anything is unclear, we urge you to inquire about them from your local fire inspector or the manufacturer.

According to official regulations chimney fires, even extinguished ones, must always be reported to the fire department.

The chimney must be inspected after every chimney fire due to the high temperatures in it.

Warning: Neglecting these instructions or official regulations may lead to damage in the chimney and fires or other hazardous situations.

5.1. Warranty

Kastor products are of high quality and reliable. Kastor grants a warranty of 10 years for manufacturing defects on its Chimneys.

The warranty does not extend to damage caused by incorrect use or disregard of these instructions. See chapter 3.

5.2. Technical data

The Kastor Chimney has been CE certified according to the requirements for metal chimneys in SS-EN 1856-1:

Certificate CE 0036 CDP 90286 001
KASTOR CHIMNEY -
SS-EN 1851-1: T600 N1 D V3 L50060 G50
SS-EN 1851-1: T600 N1 W V2 L50060 O50

SS-EN 1856-1 product standard
T600 temperature class
N1 pressure class
D/W condensation class
V3/V2 corrosion class
L50060 material class
G50 chimney fire class, safety distance to flammable structures

T600 Temperature class:

The chimney's maximum operating temperature, which may not be exceeded by flue gas = 600°C/1112°F.

D/W usage classes:

The Kastor Chimney has been certified for the flue gases of both dry (D, wood and pellet operated) and wet (W, gas and thin oil operated) fireplaces and furnaces.

L50060 Material type and thickness:

Stainless, acid-proof steel, 1 mm.

G Chimney fire class:

The Kastor Chimney can withstand chimney fires.

The safety distance to flammable structures is 50 mm.